

18G85G 18GS85G

Indoor Emergency Safety Shower Type: Combination, Top Water Inlet

Floor mounted unheated emergency safety shower with stainless steel eye/face wash unit, available with either galvanized mild steel or 316L stainless steel pipework. These ANSI compliant models are ideal for use in indoor applications not subject to the possibility of freezing or overheating. Includes universal eye wash and shower sign for enhanced visibility.

Specifications

MATERIALS OF CONSTRUCTION	
PIPEWORK AND FITTINGS (G)	Galvanized mild steel tubulars and fittings
PIPEWORK AND FITTINGS (GS)	Stainless steel tubulars and fittings
OPERATING VALVES	316L stainless steel, two piece stay open valve
SHOWER SPRAY OUTLET	Machine molded nylon 6 red shower nozzle
EYE/FACE WASH BOWL	316L stainless steel
EYE WASH DIFFUSERS	Chrome plated brass with stainless steel mesh
SERVICES	
WATER INLET	1 1/4 in Female NPT
DESIGN OPERATING PRESSURE	2.0 to 6 BAR G (29 to 87 PSI)
TEST PRESSURE	10.3 BAR G (149 PSI)
MINIMUM FLOW AT OPERATING PRESSURE	Shower: 76 liters/minute minimum (20 US Gallons). Eye/face wash: 11.4 liters/minute minimum (3 US Gallons)
ENVIRONMENTAL OPERATING TEMPERATURE	
MINIMUM AMBIENT OPERATING TEMPERATURE	5° C (41° F)
MAXIMUM AMBIENT OPERATING TEMPERATURE	35° C (95° F)
OPERATIONAL	
SHOWER SPRAY OPERATION	Pull handle
EYE/FACE WASH OPERATION	Push plate operated
NOMINAL WEIGHTS and DIMENSIONS	
DIMENSIONS - STANDARD ORIENTATION (W x D x H)	314 mm (12.4 in) x 751 mm (29.5 in) x 2617 mm (103 in) Height includes sign
WEIGHT (NO OPTIONS)	16 kg (35 lb)



shown with
optional treadle

HUGHES



Justrite Safety Group

RM07297 RevA

hughes-safety-showers.com

Indoor Emergency Safety Shower Type: Combination

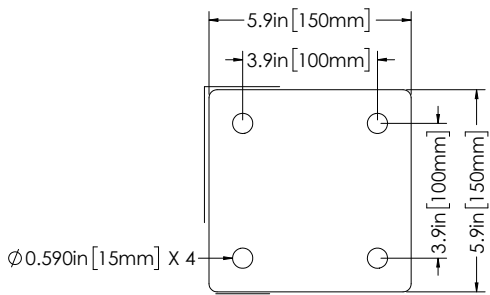
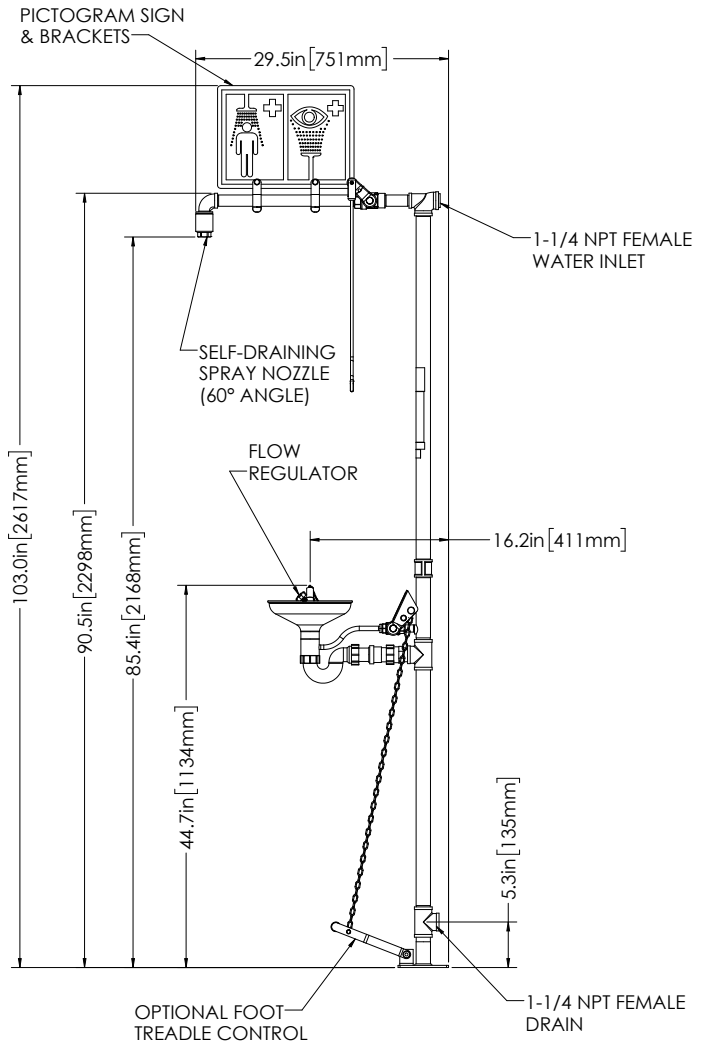
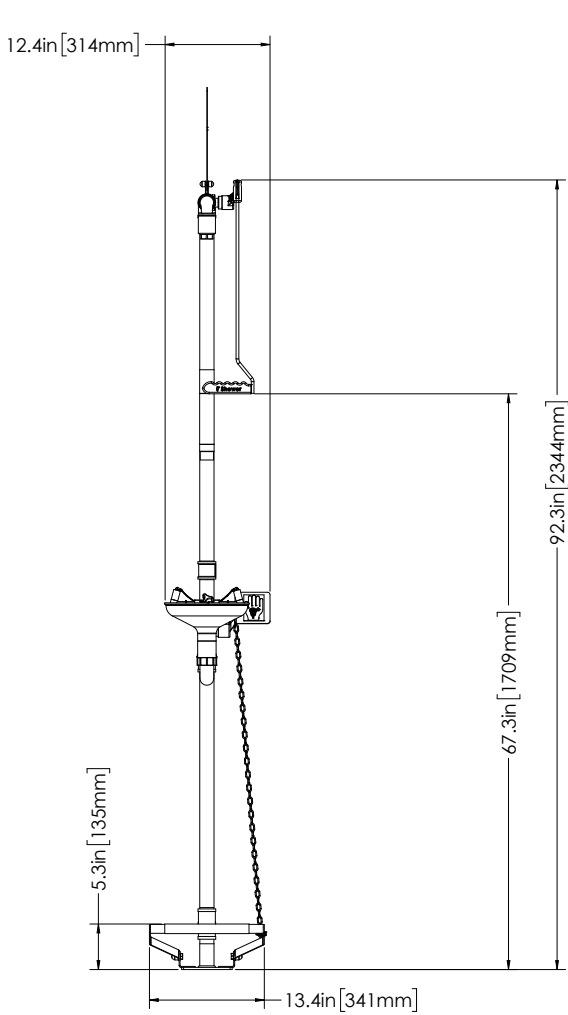

FLOOR MOUNTING PLATE VIEW
(MOUNTING HARDWARE NOT INCLUDED)

VARIATIONS IN MANUFACTURING AND ASSEMBLY
ALLOW FOR ±1/8 IN [3MM] PER THREADED JOINT.

For Technical Support Contact:
customer.service@hughes-safety.com • 1-866-312-1652

For Reorder & Sales Support Contact:
custserv@justrite.com • 1-800-798-9250



HUGHES-SAFETY-SHOWERS.COM
Justrite Safety Group

Hughes North America
457 Campbell Street
Sarnia, Ontario N7T 2J1, Canada.